

Herkules

Betriebsanleitung

Operating Instructions

Instructions d'utilisation

Deutsch	1–14
English	15–28
Français	29–42

See the list of countries and
Guarantee and Liability on pages 43–44.

English

Herkules

Microwave motion detector
for industrial doors

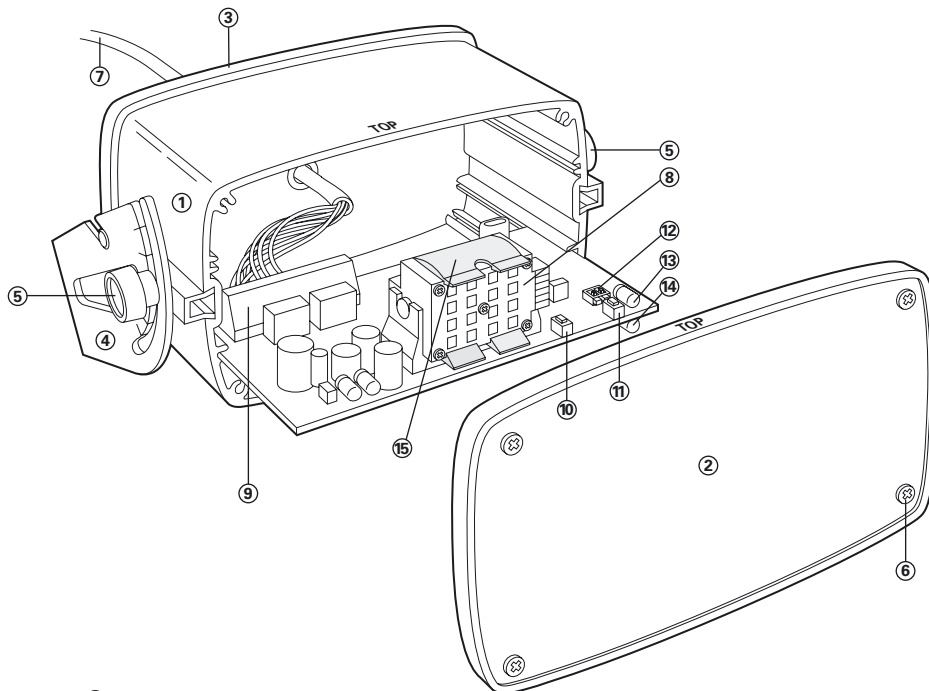

- | | |
|-----------------------|---------------------|
| ① Housing | ⑨ Screw terminal |
| ② Front cover | ⑩ Push-button X |
| ③ Rear cover | ⑪ Push-button Y |
| ④ Fixing bracket | ⑫ Switch addressing |
| ⑤ Retaining screws | ⑬ Red LED |
| ⑥ Cover screws | ⑭ Green LED |
| ⑦ Cable | ⑮ Clip |
| ⑧ Radar planar module | |

Table of contents

Chapter	Page
1 Safety instructions	16
2 Mounting.....	16–17
3 Electrical connections.....	18
4 Switch-on and initialisation	18
Reglobeam remote control	
5 Function	18–20
6 Access code	20
Motion detector settings	
7 Programming using the remote control unit	21–22
8 Programming using the push-buttons (without the remote control unit)	23
9 Mechanical settings of the radar field	24
10 Testing the field settings	24
General functions	
11 Manual door opening	24
12 Access code.....	24
13 Resetting	24
Overview of functions (remote control)	25
Enhanced function overview	26
Field dimensions of the motion detector	26–27
Technical data	28
Declaration of conformity	28
List of countries	43
Guarantee and liability	44

1 Safety instructions



The unit may only be operated at protective low voltage in conjunction with safe electrical isolation. The unit may only be repaired by the supplier. Never touch any electronic components of the sensor.

2 Mounting



Important notes:

- The unit must be firmly attached to a sturdy surface (no significant vibrations)
- Never install the unit behind a cover
- Install the unit so that unwanted moving objects cannot enter the detection zone
- Make sure there are no fluorescent lamps in the detection zone
- Install the unit in the middle above the door

2.1 Dimensions

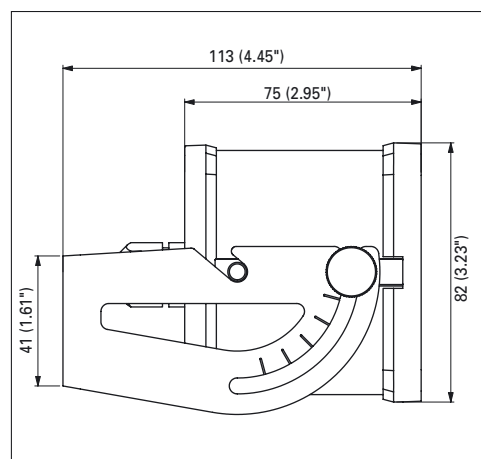
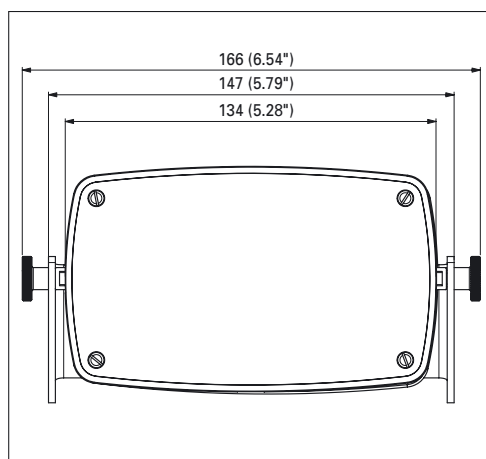

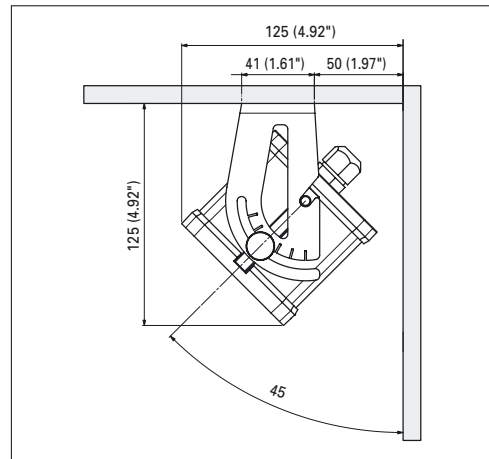
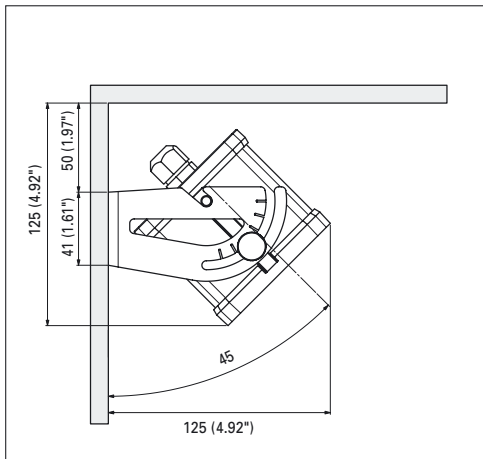

2.2 Drill holes

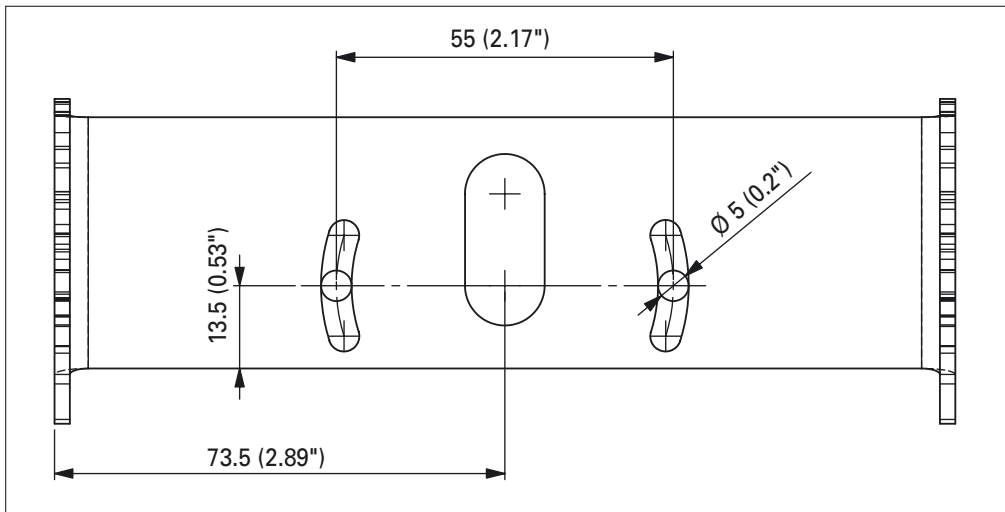

2.3 Fastening

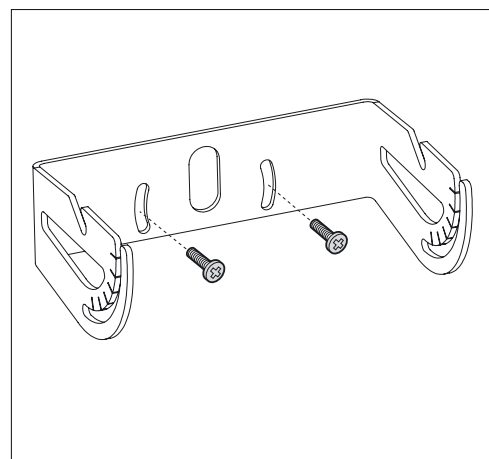
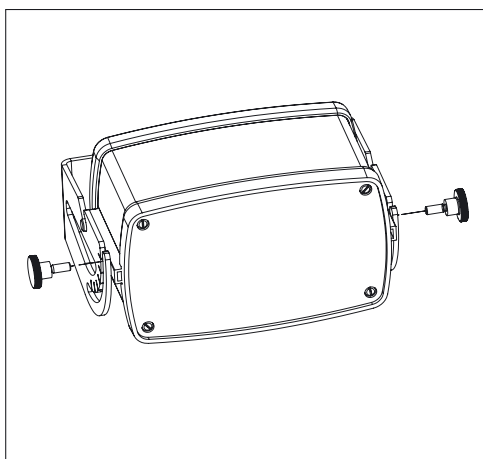

3 Electrical connection

3.1 Pin assignment

If the industrial door control only has one relay input, it is possible to connect whichever of the signals is required.

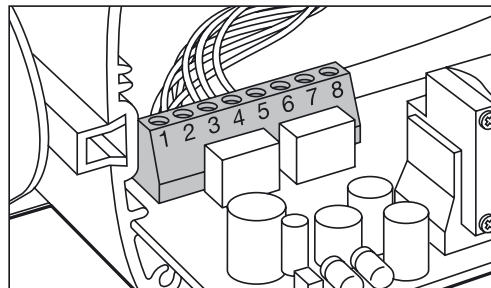

Connection when separation between people and vehicles switched ON

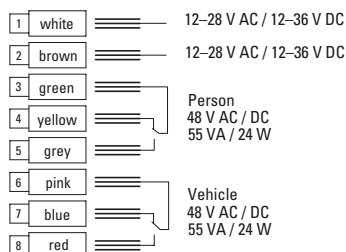

Connection for direction recognition Separation between people and vehicles switched OFF

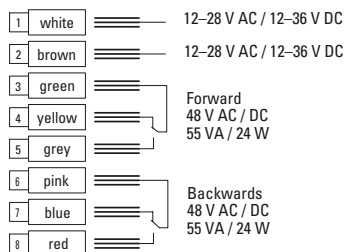

4 Switch-on and initialisation

The unit is ready for setting when the supply voltage has been connected, once the green LED has flashed several times.

The default setting is suitable for the following applications:

- Mounting height 4.00 to 4.90 m (13.1 to 16.1 ft)
- Relay hold interval 2 s, output active
- Slow motion detection on medium level (detection of very slow objects)
- Separation between people and vehicles active
- Crossing traffic masking on medium level
- Detection of movements towards the detector (forwards)

If other settings are required, then they can be changed using the remote control or with the push-buttons. Refer to chapter 8 for information about setting with push-buttons.

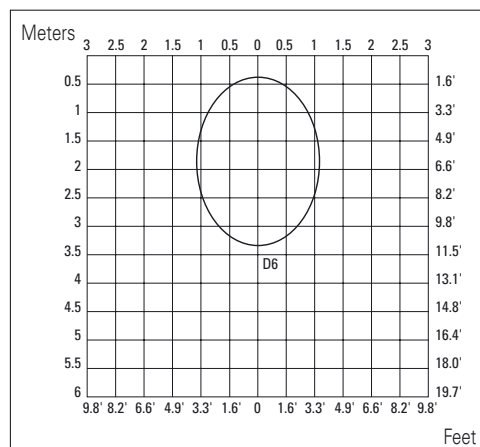

Field dimension with mounting angle 30°

Reglobeam remote control unit

The Reglobeam remote control unit allows you to program the Herkules easily and conveniently from floor level. Data transfer between the Reglobeam and the Herkules takes place in both directions, i.e. to and from the sensor; it is ensured by

an infrared interface. The set values are read back by the Reglobeam immediately after programming, and are displayed so that they can be checked. This ensures a safe and correct programming.

5 Function

The Reglobeam is operated via a combination of function and numerical keys. Note the correct method of operation as per chapters 5ff and 7ff.

Flashing keys on the Reglobeam mean that data transfer was incomplete. The infrared interface should not be exposed to direct sunlight and other light sources.

5.1 Lay-out

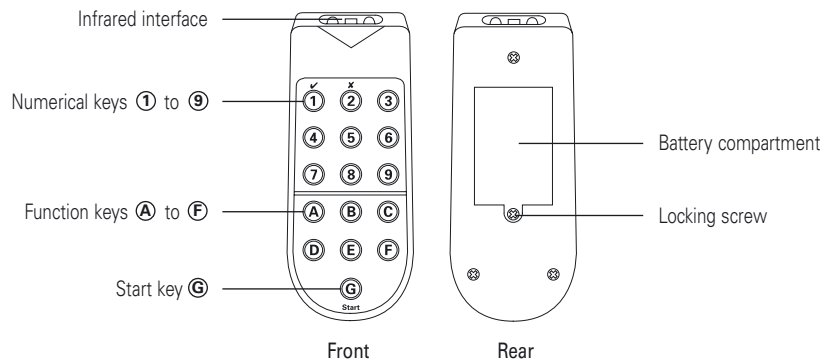

5.2 Configuration mode

A connection between the Reglobeam and the Herkules can only be established if the sensor is in configuration mode. Configuration mode is activated after the sensor has been switched on. For safety reasons this mode is automatically deactivated 30 minutes after the last setting has been made at the sensor.

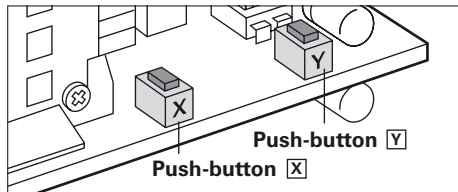

There are three different ways of activating configuration mode:

- Press either of the **X** or **Y** push-buttons located on the sensor
or
- Restart the sensor
(disconnect the supply voltage)
or
- Gain access to configuration mode via an access code
(see chapter 6ff)

5.3 Making the connection

Press start key ⑦ located on the Reglobeam.

- If the connection has been made successfully, ⑦ and one of the keys ① to ④ lights up (see also section 5.4 for sensor address).
- No connection could be established if ⑦ flashes.
 - Hold the remote control unit closer and aim it at the sensor.
 - Check the batteries in the Reglobeam.

- If no keys light up on the Reglobeam, replace the batteries.
- If ⑦ and one of the keys ① to ④ light up, but no further settings are possible, then configuration mode is not activated.
 - Activate configuration mode (section 5.2)

5.4 Addressing the sensor

Four different addresses for communicating with the Reglobeam can be set at the sensor.

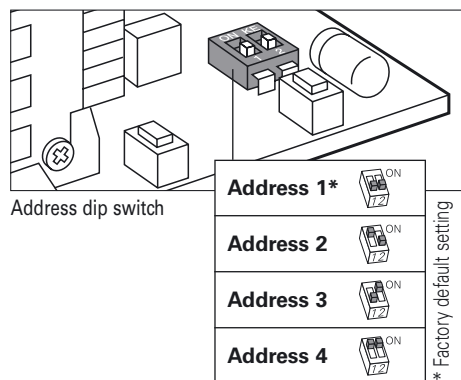

Different methods of addressing the sensors must be used in the two cases below:

- Several sensors are located within range of remote control unit. This can occur with sensors which are located next to each other, but also with sensors located opposite each other.
- Choose different addresses
 - Make the connection between the sensor and remote control unit as per section 5.3.

6 Access code

The Herkules can be protected against undesired manipulation by means of a four-digit access code. With this code, configuration mode can be reactivated at any time via remote control unit (see also section 5.2) in order to adjust settings. The default setting for the "access code" function is OFF.

6.1 Switching on the "access code" function (saving the code)

The code can only be saved if the sensor is already in configuration mode (see section 5.2). The unit is protected as soon as the code has been saved (configuration mode is deactivated).

1. Press the start key **Ⓞ**
→ **Ⓞ** and one of the keys **①** ... **④** light up
2. Press **Ⓞ** and then **⑨**
→ **Ⓞ** and **②** light up
→ "Access code" function is switched off
(no code is saved)
3. Enter four-digit code
(any number from 1111 to 9998 can be chosen)
4. Press **Ⓞ**
→ **Ⓞ** and **①** light up
→ "Access code" function is switched on
(code is saved)
→ Configuration mode is deactivated
(unit is protected)

6.2 Switching off the "access code" function (clearing the code)

The code may only be cleared when the sensor is in configuration mode (see section 5.2).

1. Press the start key **Ⓞ**
→ **Ⓞ** and one the keys **①** ... **④** light up
2. Press **Ⓞ** and then **⑨**
→ **Ⓞ** and **①** light up
→ "Access code" function is switched on
3. Press **⑨** our times and then press **Ⓞ**
→ **Ⓞ** and **②** light up
→ "Access code" function is switched off
(code is cleared)

6.3 Activating configuration mode

Configuration mode can only be activated by remote control unit if a code has been saved previously (see section 6.1).

1. Press the start key **Ⓞ**
→ **Ⓞ** and one of the keys **①** ... **④** light up
2. Press **Ⓞ** and then **⑨**
→ **Ⓞ** and **①** light up
→ "Access code" function is switched on
3. Enter your four-digit code
4. Press **Ⓞ**
→ **Ⓞ** and **①** light up
→ Configuration mode is activated
→ Sensor is ready to be programmed
→ If **Ⓞ** and **②** light up, then the code entered is wrong
→ Start again at step 1.

6.4 Switching off the "access code" function (clearing the code) without the remote control unit

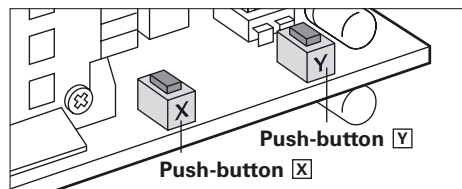

Push-buttons

Important: all unit parameters are set to factory default.

- Press the push-buttons **X** and **Y** simultaneously for 8 seconds. Both LEDs light up briefly every two seconds.
- Unit is reset to its default settings
 - "Access code" function is switched off (code is cleared)
 - A new initialisation and teach-in phase begins (see chapter 4)

Motion detector settings

7 Programming using the remote control unit

Refer to chapter 8ff for programming without the remote control unit.
The table on page 25 provides an overview of all functions with values and factory settings.

Notes

- Remote control unit: see chapter 5ff for Reglobeam functions
- Programming must be carried out within 30 s, otherwise you will have to restart the process

7.1 Mounting height

ⓕ + ④ + ② ... ⑦ (levels 2 to 7)

2 = 2.50 to 2.90 m (8.2 to 9.5 ft)
3 = 3.00 to 3.90 m (9.8 to 12.8 ft)
4 = 4.00 to 4.90 m (13.1 to 16.1 ft)
etc.

The mounting height must always be entered
(factory setting 4.00–4.90 m, 13.1–16.1 ft).

7.3 Field size (sensitivity)

ⓕ + ① ... ⑨

Levels 1 (small field) to 9 (large field)

Refer to page 26–27 for field dimensions.

7.2 Comfort functions

These pre-programmed settings are designed for quick and easy configuration in the case of standard applications.

- ⓕ + ① = Standard, detects all objects
- ⓕ + ② = Frontal traffic, all objects
- ⓕ + ③ = Lateral traffic, all objects
- ⓕ + ④ = High sensitivity, all objects
- ⓕ + ⑤ = Standard, P/V separation¹
- ⓕ + ⑥ = Frontal traffic, P/V separation¹
- ⓕ + ⑦ = Lateral traffic, P/V separation¹
- ⓕ + ⑧ = High sensitivity, P/V separation¹
- ⓕ = Read comfort level

¹Separation between people and vehicles

Remote control unit read back and display comfort function even if several parameters were changed.

The pre-programmed values of the enhanced functions are shown in the "enhanced functions" overview table on page 26.

7.4 Relay hold interval (additional hold interval)

ⓕ + ① + ① ... ④ (levels 1 to 4)

1 = 0.5 s
2 = 1.0 s
3 = 2.0 s
4 = 5.0 s

The additional hold interval only starts after other functions have taken place with delayed effect.

7.5 Direction recognition

- Ⓔ + ① = Detection of objects moving towards the detector (forwards)
- Ⓔ + ② = Detection of objects moving away from the detector (backwards)

Direction recognition can only be used and changed if the people/vehicle separation function is active (section 7.7). Otherwise, the direction of the object is displayed separately by the two outputs.

7.6 Output signal active/passive

- Ⓔ + ② + ① = Active
- Ⓔ + ② + ② = Passive

The factory connections of the relay outputs are shown in section 3.1. This function enables the connection type to be changed without having to swap over the connection cables.

7.7 Separation between people and vehicles

- Ⓔ + ⑧ + ① = On, i.e. the sensor sends signals to separate relay outputs
- Ⓔ + ⑧ + ② = Off, i.e. the sensor signals the direction of the object to the outputs irrespective of the type of the object

Using this function, it is possible to select whether the relay outputs should be switched separately in response to people or vehicles.

7.8 Cross-traffic optimisation

- Ⓔ + ⑤ + ① = Off
- Ⓔ + ⑤ + ② ... ⑨ (levels 2 to 9)

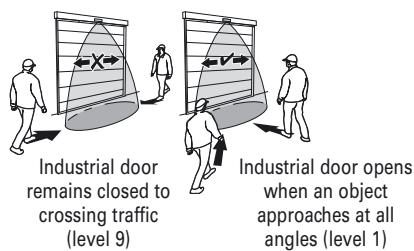

Optimum inclination angle for crossing traffic function: 30° to 45° (also refer to section 9.1).

Using cross-traffic optimisation with the clip is not possible.

7.9 Wide field

- Ⓔ + ① = On
- Ⓔ + ② = Off

This function must be activated when the mechanical clip is used for setting a wide field. Also refer to section 9.2.

7.10 Slow motion detection (SMD)

- Ⓔ + ③ + ① = OFF
- Ⓔ + ③ + ② ... ⑤ = decreasing sensitivity
- Ⓔ + ③ + ⑥ ... ⑨ = constant sensitivity

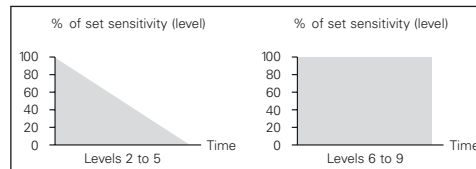

SMD levels

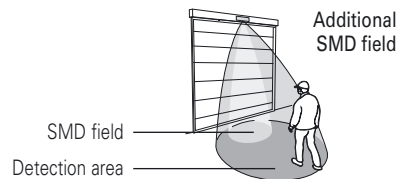

The additional SMD field is activated after detection is made; it makes it possible to monitor a person who remains in the door area. The SMD function recognises the slightest movements, thus providing a marked increase in convenience in the extended door area. The size of the SMD field can be adjusted to 9 different levels (see section 7.11).

7.11 Field size SMD

- Ⓔ + ⑦ + ① ... ⑨ (levels 1 to 9)

This function is used to set the size of the SMD field:

1. Set the "additional fall-delay time" function (section 7.4) to its lowest value (F + 1 + 1).
2. Set the required field size to the following levels:
 - 1-3 = small
 - 4-6 = medium
 - 7-9 = large
3. After checkout the field reset the "additional fall-delay time" (section 7.4) to the previous value.

Consider that the position of the SMD field is influenced by the inclination angle of the radar module (see sections 9.1).

7.12 Digital filter functions

- Ⓔ + ⑥ + ① = On
- Ⓔ + ⑥ + ② = Off

Herkules can be used in numerous applications with different environmental influences. In some special mounting situations, it may be necessary to activate an additional filter for interference suppression. This happens when nearby sources of interference lead to unwanted false tripping. The problem can be addressed using this function.

8 Programming using the push-buttons (without the remote control unit)

If you make the settings with the Reglobeam remote control unit, see chapter 7ff. For an overview of all functions with values and factory settings see the table on page 25.

Note

- Programming must be carried out within 30 s.
- After this time, programming mode must be reactivated.

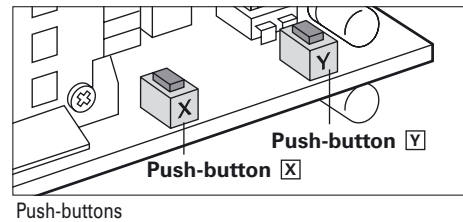

8.1 Setting the functions

Functions are set and all parameters are reset by pressing the push-buttons.

Step 1

Press both push-buttons at the same time to access the required mode

- Primary mode → Press both push-buttons for 2 s → Green LED flashes after 2 s
- Secondary mode → Press both push-buttons for 4 s → Green LED flashes after 2 s and after 4 s
- Reset → Press both push-buttons for 8 s → Green LED flashes after 2 s, after 4 s and after 8 s

The green LED then flashes the number of the activated function, the red LED outputs the current level by flashing accordingly.

Step 2

Change the function by pressing the push-button X (value is increased by one per push-button press). Once the last function has been reached, the program jumps back to the first function.

Change the level by pressing the push-button Y (value is increased by one per push-button press).

Step 3

Exit programming mode by pressing both push-buttons briefly at the same time.

The values that can be set in both modes are shown in the table below.

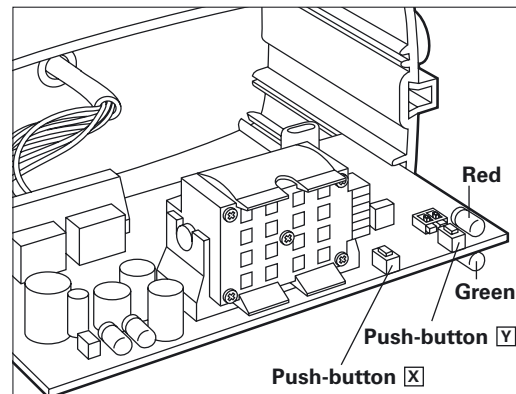

Mode	Function	Step 1	Step 2		Notes
		Both push-buttons at same time	Push-button X No. of function (Green LED)	Push-button Y Level (Red LED)	
Primary	Comfort level	Press for 2 s	①	①...⑧	Section 7.2
	Mounting height	Press for 2 s	②	②...⑦ 2 = 2.50–2.90 m (8.2–9.5 ft) 3 = 3.00–3.90 m (9.8–12.8 ft) 4 = 4.00–4.90 m (13.1–16.1 ft)* etc.	
Secondary	Field dimensions	Press for 4 s	①	①, ②, ③ Small ④, ⑤, ⑥ Medium* ⑦, ⑧, ⑨ Large	
	Relay hold interval	Press for 4 s	②	① = 0.5 s ② = 1.0 s ③ = 2.0 s* ④ = 5.0 s	
	Direction recognition	Press for 4 s	③	① Forwards = Towards detector* ② Backwards	
	Active/passive	Press for 4 s	④	① Aktive * ② Passive	
	Separation between people and vehicles	Press for 4 s	⑤	① On* ② Off	

* Factory setting

9 Mechanical settings of the radar field

9.1 Tilting the radar detector

Range: 0° to 90°, adjustable in 30° steps

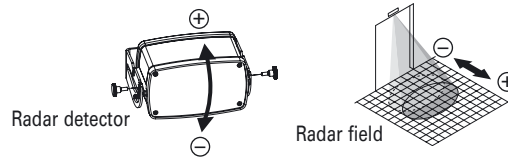

9.2 Detection field geometry (clip)



The clip can only be used for mounting heights up to 4 m (13.1 ft). The field geometry is altered using the clip. The operating voltage must be interrupted for at least 5 seconds every time the clip is put on or removed.

Field without clip

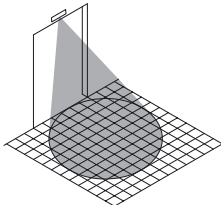

Field with clip

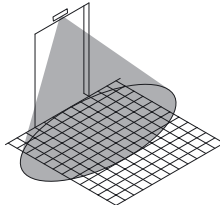

The wide field must be activated using the key combination **ⓐ** + **ⓑ** after the clip is fitted. Refer to section 7.9.

Mounting the clip

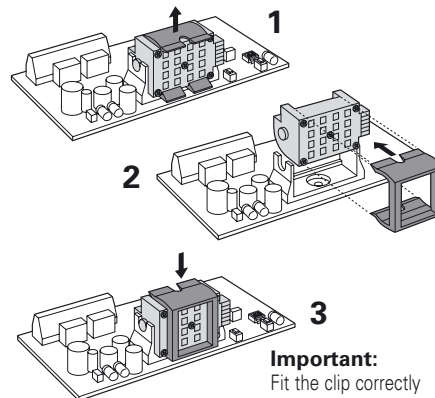

Important:
Fit the clip correctly

10 Testing the field settings

Check that the field settings are correct by pacing across the detection field and observing the corresponding LED. Refer to page 26 ff. for field dimensions.

LED	Separation between people and vehicles switched ON	Direction recognition
Red	Detecting people	Forwards recognition
Green	Detecting vehicles	Backwards recognition

General functions

11 Manual industrial door opening

- ⓐ + **ⓑ** = Switch on relay
- ⓐ + **Ⓒ** = Switch off relay

Manual industrial door opening remains active for max. 15 minutes unless the function is switched off again. Then the industrial door closes and automatic mode is reactivated.

12 Access code

Please see chapter 6.

13 Reset

This function resets all the sensor's parameters to the factory default settings (see page 25, "Overview of remote control unit functions") and a new initialisation phase begins when the unit is switched on (see chapter 4).

Furthermore, the access code is cleared when the system is reset (chapter 6ff).

There are two ways of resetting the unit back to factory default:

- a) using the remote control unit
ⓐ + **ⓓ** = reset
- or
- b) using the push-buttons
Press **ⓧ** and **Ⓨ** simultaneously for 8 seconds.
Both LEDs light up briefly every two seconds.

Overview of functions (remote control)

Chapter	Function	Description	Key combination	Levels
6 (12)	Access code	Read code status Set code Enter code Delete code	C + 9 C + 9 + X X X X + C C + 9 + X X X X + C C + 9 + 9 9 9 + C	① = Code saved ② = No code Set 1111–9998 Enter 1111–9998
7.2	Comfort functions	Read comfort level Select comfort level	C C + 1 ... 8	see section 7.2
7.1	Mounting height	Read mounting height Set mounting height	F + 4 F + 4 + 2 ... 7	② = 2.5–2.9 m (8.2–9.5 ft) ③ = 3.0–3.9 m (9.8–12.8 ft) ④ = 4.0–4.9 m (13.1–16.1 ft)* etc.
7.3	Field dimensions (sensitivity)	Read sensitivity Select sensitivity	D D + 1 ... 9	see section 7.3 ①, ②, ③ = Small ④, ⑤, ⑥ = Medium* ⑦, ⑧, ⑨ = Large
7.4	Relay hold interval (additional hold interval)	Read hold interval Set hold interval	F + 1 F + 1 + 1 ... 4	① = 0.5 s ② = 1.0 s ③ = 2.0 s* ④ = 5.0 s
7.5	Direction recognition (Only when separation between people/vehicles is active)	Read direction Select direction	E E + 1 ... 2	① = Forwards* ② = Backwards
7.6	Output signal active/passive	Read active/passive mode Set active/passive mode	F + 2 F + 2 + 1 ... 2	① = Active* ② = Passive
7.7	Separation between people and vehicles (P/V separation)	Read P/V separation Switch P/V separation on/off	F + 8 F + 8 + 1 ... 2	① = On* ② = Off
7.8	Cross-traffic optimisation (CTO)	Read CTO-level Set CTO-level	F + 5 F + 5 + 1 ... 9	① = Off ②, ③ = Low ④, ⑤, ⑥ = Medium* ⑦, ⑧, ⑨ = High
7.9	Wide field (Only when the clip is used)	Read wide field function Select wide field function	B B + 1 ... 2	① = On ② = Off*
7.10	Slow Motion Detection (SMD) (Detecting very slow-moving objects)	Read SMD level Set SMD level	F + 3 F + 3 + 1 ... 9	① = Off, no SMD ②, ③ = Short, decreasing* ④, ⑤ = Long, decreasing ⑥, ⑦ = Short, constant ⑧, ⑨ = Long, constant
7.11	SMD field dimensions	Read SMD field dimensions Set SMD field dimensions	F + 7 F + 7 + 1 ... 9	①, ②, ③ = Small ④, ⑤, ⑥ = Medium* ⑦, ⑧, ⑨ = Large
7.12	Digital filter function	Read interference suppression status Switch interference suppression on/off	F + 6 F + 6 + 1 ... 2	① = On ② = Off*
11	Manual industrial door opening	Read relay status Switch on relay Switch off relay	A A + 1 A + 2	
13	Reset	Initialise unit	A + 9	

* Factory settings

Enhanced function overview

Key combination	Ⓒ + ①	Ⓒ + ②	Ⓒ + ③	Ⓒ + ④	Ⓒ + ⑤ ¹⁾	Ⓒ + ⑥	Ⓒ + ⑦	Ⓒ + ⑧
Detection	All objects				Separately for people/vehicles			
Designation	Standard	Front	Side	Sensitive	Standard	Front	Side	Sensitive
Application	General	Main traffic frontally towards detector	Main traffic laterally towards detector	Detects slow objects and large field	General	Main traffic frontally towards detector	Main traffic laterally towards detector	Detects slow objects and large field
B: Wide field	Off	Off	On ²⁾	Off	Off	Off	On ²⁾	Off
D: Field Dimensions	Medium	Medium	Medium	Large	Medium	Medium	Medium	Large
E: Direction	Not active	Not active	Not active	Not active	Forw.	Forw.	Forw.	Forw.
F1: Relay time	2 s	2 s	2 s	2 s	2 s	2 s	2 s	2 s
F2: Active / passive	Active	Active	Active	Active	Active	Active	Active	Active
F3: Slow Motion Detection	2	2	2	8	2	2	2	8
F4: Mounting height	4.00–4.90 m (13.1–16.1 ft)	4.00–4.90 m (13.1–16.1 ft)	3.00–3.90 m (9.8–12.8 ft)	4.00–4.90 m (13.1–16.1 ft)	4.00–4.90 m (13.1–16.1 ft)	4.00–4.90 m (13.1–16.1 ft)	3.00–3.90 m (9.8–12.8 ft)	4.00–4.90 m (13.1–16.1 ft)
F5: Cross-traffic optimisation	Medium	High	Low	Low	Medium	High	Low	Low
F6: Filter	Off	Off	Off	Off	Off	Off	Off	Off
F7: SMD field	Medium	Medium	Medium	Medium	Medium	Medium	Medium	Medium
F8: P+V Detection	Off	Off	Off	Off	On	On	On	On

¹⁾Factory setting ²⁾Insert the clip, see 9.2

Field dimensions of the motion detector

Typical values. Discrepancies are possible due to tolerances. Dimensions in meters and feet.

Mounting height 2.5 m (8.2 ft)

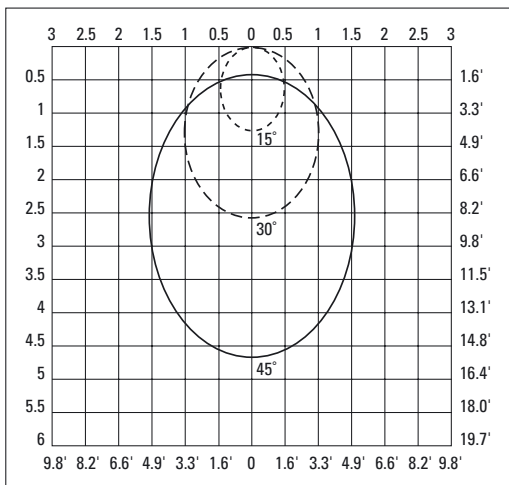

Max. field dimension D9
Mounting angle 15°, 30°, 45°

Mounting height 2.5 m (8.2 ft)

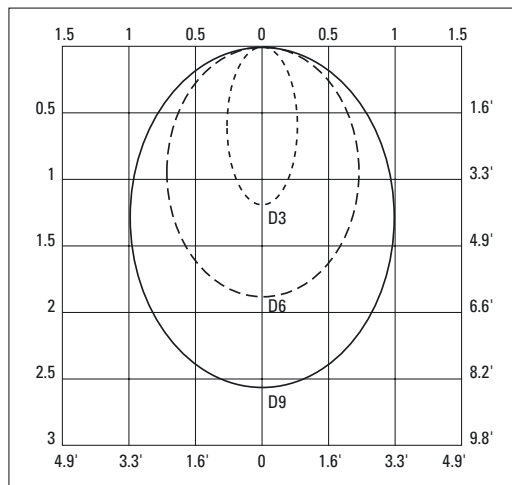

Mounting angle 30°
Field dimension D3, D6, D9

Mounting height 4.5 m (14.75 ft)

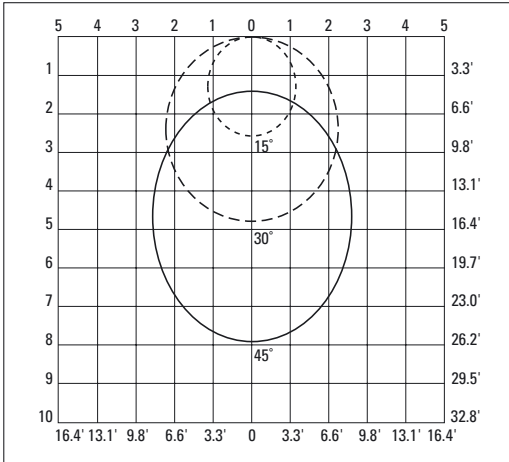

Max. field dimension D9
Mounting angle 15°, 30°, 45°

Mounting height 4.5 m (14.75 ft)

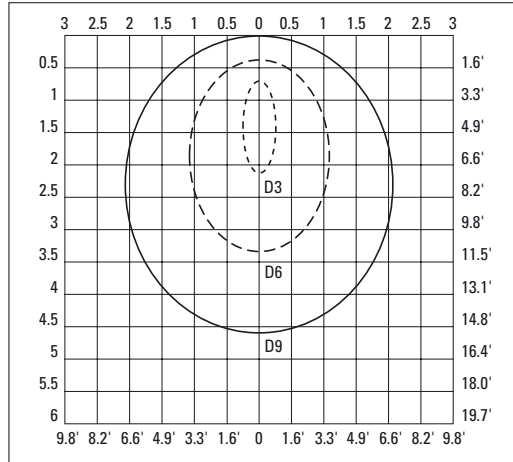

Mounting angle 30°
Field dimension D3, D6, D9

Mounting height 7 m (23.0 ft)

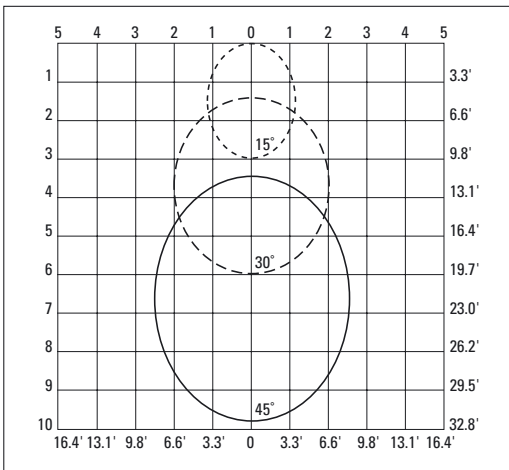

Max. Field dimension D9
Mounting angle 15°, 30°, 45°

Mounting height 7 m (23.0 ft)

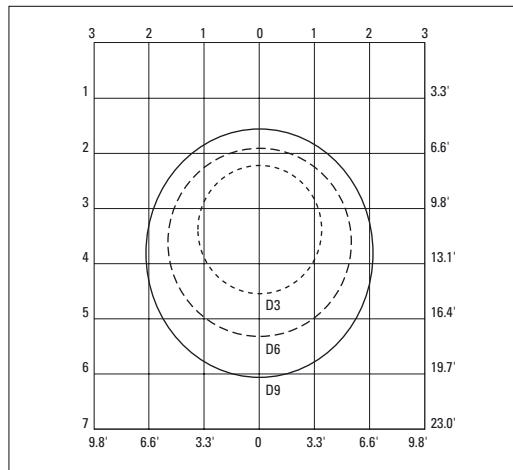

Mounting angle 30°
Field dimension D3, D6, D9

Mounting height 3 m (9.8 ft) (wide field with clip)

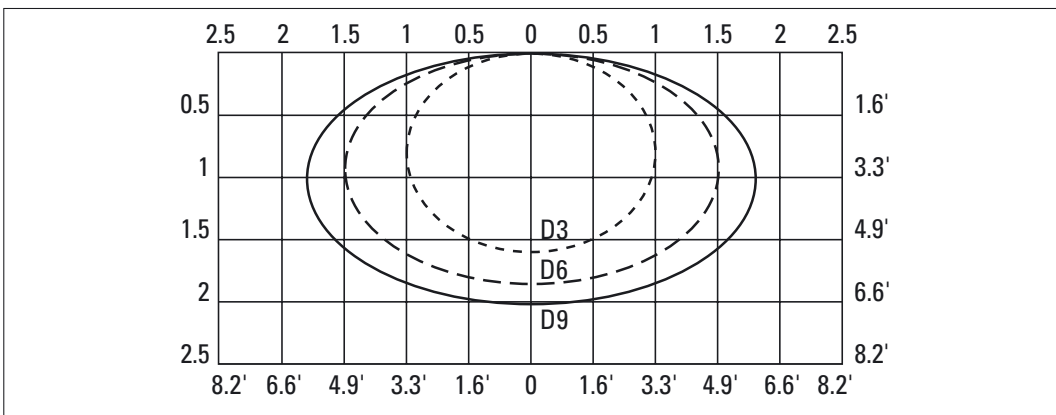

Mounting angle 30°
Field dimension D3, D6, D9

Technical data

Motion detector		
Technology	Doppler microwave with planar module	Frequency = 24.05 ... 24.25 GHz
Mounting height	2.5 m to 7 m (8.2 ft to 23 ft)	
Outputs	2 potential-free changeover contacts For separation of – People/vehicles – Direction recognition	Max. switching voltage 48 V AC/DC Max. switching current 0.5 A AC / 1.0 A DC Max. switching capacity 55 VA / 24 W ohmic load
Connection cable	8 x 0.14 mm ² (AWG 26), length 5 m (16.40 ft)	Connected to screw terminal
Detection speeds	Max. 25 km/h (15 mph) for vehicles	
Response time	< 100 ms	
Max. Range	25 m (82 ft)	At 4.5 m (14.75 ft) mounting height and max. field dimensions
Operating voltage	12–28 V AC, 12–36 V DC	
Operating current	Max. 110 mA	At 24 V AC, 20° C (68° F)
Current at make	Max. 1 A	At pulse width > 20 µs
Material	Aluminium housing, polycarbonate cover	Colour black
Dimensions	134 x 82 x 75 mm (5.28" x 3.23" x 2.95")	W x H x D
Protection class	Suitable for use in acc. with IP 65	
Operating temperature	–20° to +60° C (–4° F to +140° F)	
Humidity	0% to 95% relative, without condensation	
EMC	Directive 89/336/EEC, edition 1996 EN 61000-6-2 EN 61000-6-3	
Weight	720 g (1.587 lb) incl. cable	
Approval	CE 0682 0 / FCC / IC	

FCC-Approval

This device complies with Part 15 of the FCC Rules and with RSS-210 of Industry Canada.

Operation is subject to the following two conditions:

- this device may not cause harmful interference, and
- this device must accept any interference received, including interference that may cause undesired operation.

This equipment has been tested and found to comply with the limits for a Class B digital device, pursuant to part 15 of the FCC Rules. These limits are designed to provide reasonable protection against harmful interference in a residential installation. This equipment generates, uses and can radiate radio frequency energy and, if not installed and used in accordance with the instructions, may cause harmful interference to radio communications. However, there is no guarantee that interference will not occur in a particular installation. If this equipment does cause harmful interference to radio or television reception, which can be determined by turning the equipment off and on, the user is encouraged to try to correct the interference by one or more of the following measures:

- Reorient or relocate the receiving antenna
- Increase the separation between the equipment and receiver
- Connect the equipment into an outlet on a circuit different from that to which the receiver is connected
- Consult the dealer or an experienced radio/TV technician for help



Warning: Changes or modifications made to this equipment not expressly approved by Bircher Reglomat AG may void the FCC authorization to operate this equipment.

EC Declaration of Conformity

Bircher Reglomat AG herewith declares the product Herkules to be in conformance with the basic requirements and other relevant regulations as contained in the 1999/5/EG directive.

The full version of the Declaration of Conformity can be viewed on our internet homepage:

www.bircher-reglomat.com