

AIR 30



WORLD OF SENSORIC WORLD OF SENSORIC

Active Infrared Detectors

AIR 30 – Active Infrared Detectors

Function / Settings / Mounting

Function

Transmitter and receiver unit are installed in a housing.

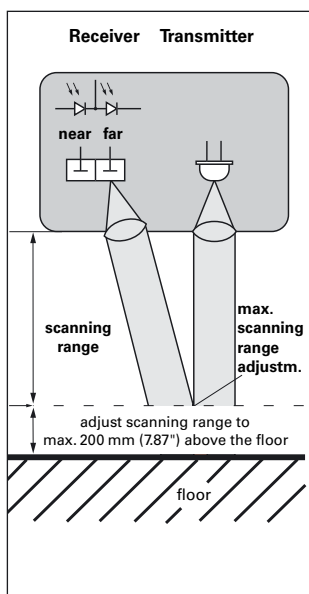
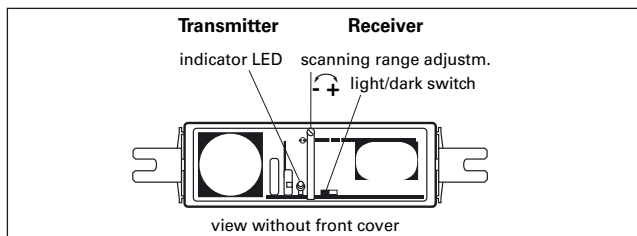

The separate optical units (transmitter and receiver) are aligned in relation to each other at a certain angle. The point of intersection of the two optical axes forms the maximum scanning range (Triangulation principle). This allows the receiver to recognize whether the infrared light emitted by the transmitter is reflected by a person/object within or without (background) the scanning range.

Positioning of the detection beam

The AIR 30 is mounted on the swivel bracket or on a standard angle, allowing it to be swivelled in 5° steps.

- Beam Ø = approx. 50 mm (1.97") at 2 m (6.56') mounting height

Operating mode

Background suppression

The background is "recognized", but not evaluated (ignored). For the switching signal a reflex signal is required from an object within the set scanning range.

- **Benefits of background suppression**
- ideal anti-collision protection in rotating or moving direction when mounted ridealong
- no background required
- independent of reflectance value of the background

Drawbacks of background suppression

- is blind at close range
- no transmitter failure message
- no possibility of testing

Background analysis

The transmitter continuously communicates with the receiver via the background (floor). Testing is done by switching off the transmitter with +UB. The background is used as a reflector. When the light beam is interrupted by an object this triggers a switching signal.

Benefits of background evaluation

- possibility of testing
- transmitter failure message
- scanning range from 100 mm (3.94") – therefore ideally suited e.g. for pedestrian safety locks
- registers also mirror-like objects (vehicles)

Drawbacks of background evaluation

- cannot be mounted ride-along
- background is required
- is dependent upon reflectance value of the background. With a black, wet and mirror-like background false signals are possible

Switching mode

Light switching

	Background suppression			Background analysis		
	LED	signal output relay	electronic	LED	signal output relay	electronic
object within scanning range	lit	attracted	active	not lit	released	not active
no object within scanning range	not lit	released	not active	lit	attracted	active

Dark switching

	Background suppression			Background analysis		
	LED	signal output relay	electronic	LED	signal output relay	electronic
object within scanning range	not lit	released	not active	lit	attracted	active
no object within scanning range	lit	attracted	active	not lit	released	not active

Test input SA

SA	switching mode	Background evaluation		
		LED	signal output	
			relay	electronic
active	light	not lit	released	not active
active	dark	lit	attracted	active

Note: it is not decisive if object is in scanning range or not.

Accessories

Weather protective cover

For protection against vandalism

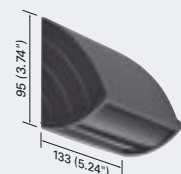

Mounting plate



Mounting frame

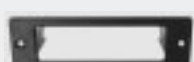

Mounting set



Inlet box

Set for flush mounting consisting of box with extendable side walls for inclination of the unit, infrared transparent housing cover with seal and cover frame for neat finish mounting.

Surface-mounting box

Same as inlet box, however without cover frame.

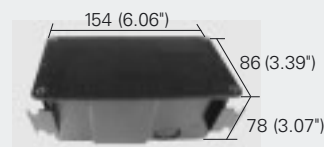

Technical Data	AIR 30/31 and AIR 30/32	Notes
Scanning range	100–2500 mm (3.9"–98.4") 550–2500 mm (21.7"–98.4")	with background analysis with background suppression
Scanning range adjustment	mech. adjustment screw 1000–2500 mm (39.4"–98.4")	triangulation principle
Scanning area of each single spot	approx. 50 x 50 mm (1.97" x 1.97")	with scanning range 2000 mm (78.7")
Type of light	IRED	pulsed alternating light
b/w-difference	< 400 mm (15.7")	with scanning range 2000 mm (78.7")
Operating voltage	AIR 30/31: 10–48 V DC / 11–36 V AC AIR 30/32: 10–30 V DC	
Residual ripple	< 10 %	with DC operation
Current consumption	< 100 mA	
Power consumption	approx. 3 W	
Signal output	AIR 30/31: relay (n. o. contact) max. switching voltage 42 V AC max. switching current 1 A / 2 W VDC max. switching capacity 24 W / 55 VA AIR 30/32: 1 PNP transistor, 0.2 A / 30 VDC	AIR 30/32 – 1 PNP transistor open collector, short-circuit proof, protected against polarity reversal
Response time	approx. 50 ms	
Switching mode	light/dark	see table of options
Test input	AIR 30/31: with +UB = 10–48 V DC AIR 30/32: with +UB = 10–30 V DC	only with background analysis
Function indication	LED red	lit when output active
Connection	cable 5 m (16.4')	
Protection class	IP52	option: protective cover
Optics surface	lexan	
Operating temperature	–20° C to +60° C (–4 °F to 140 °F)	
Weight	approx. 340 g (12 oz) incl. packing and cable	
Housing/color	ABS, black	
Electromagnetic compatibility	According to the following directive: 89/336/EEC, edition 1996 CE According to the following standards: EN 60947-5-2, edition 1998 (product standard) EN 61000-6-2, edition 2001, without EN 61000-4-5, EN 61000-4-11 EN 61000-6-3, edition 2001, Remark: according to class B of EN 55022	

Dimensions

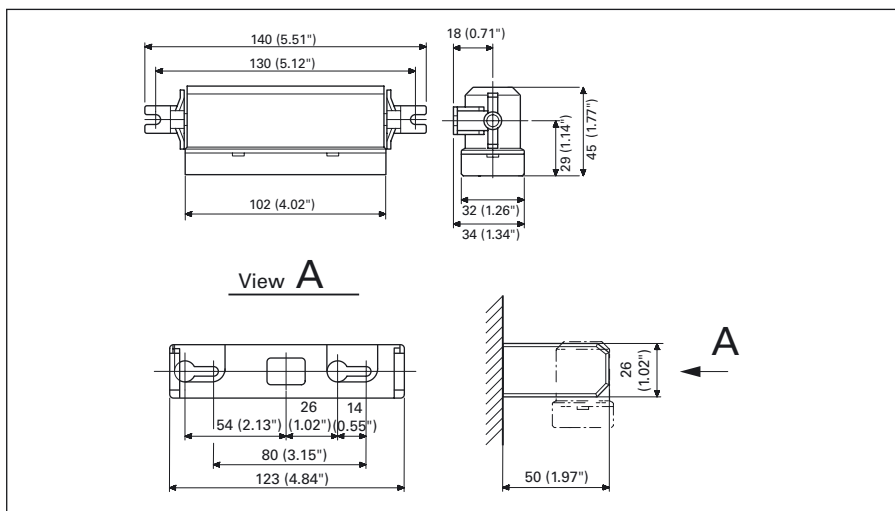

Wiring schemes

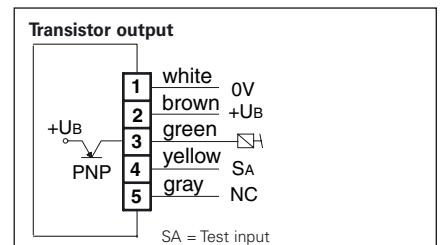
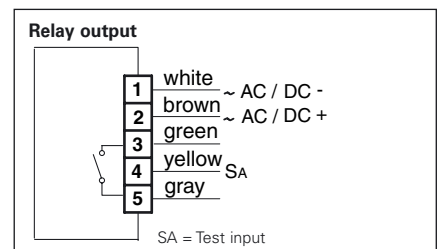

Applications



Automatic door systems

- Pinching and edge protection at revolving and sliding doors or as substitute for guard panels
- Ride-along anti-collision protection at swing doors
- Presence detectors for small areas (kitchen and service area of restaurants, hotels etc.)
- Counting of persons in shopping centers, exhibitions etc. with a person counting program

Elevators and escalators

- Pinching and edge protection at semicircular-doors
- Static cabin-access control using several vertically arranged light beams
- Cabin-occupied control (sensors mounted on the cabin ceiling)

Scope of delivery

Swivel bracket, mounting bracket, connection cable

Options

Standard versions

Designation	Article No.	Signal output			Switching mode	Presetting		Connection	Test input	Operating mode	
		PNP	NPN	relay	light / dark switchable	light	dark	cable 5 m	+UB	background suppression	background analysis
AIR 30/25/31	F511.50009			■	■	■		■	■		■
AIR 30-H/25/31	F511.50010			■	■	■		■		■	
AIR 30/31/59	F511.50033			■	■		■	■	■		■
AIR 30-H/31/59	F511.50034			■	■		■	■		■	

Special versions

AIR 30/25/32	F511.50007	■			■	■		■	■		■
AIR 30/32/59	F511.50002	■			■		■	■			■

Accessories

Article No.	Designation	Colour	Article No.	Designation	Colour
F539.39970	Mounting set	black	F539.39300	Weather protective cover	anthracite
F539.39015	Recessed mounting frame	black	F539.39320	Weather protective cover	pearl white
F539.39009	Surface mounting box	black	K7621.001	Mounting plate	black
F539.39023	Inlet box	black			

Your contact

Bircher Reglomat AG

Hauptstrasse 22
 CH-9042 Speicher
 Switzerland
 Phone +41 (0)71 343 83 83
 Fax +41 (0)71 343 83 80
 info@reglomat.com
 www.bircher-reglomat.com

Note:

Technical details and recommendations concerning our products are based on experience and are an aid for the orientation of the user. Details stated in our brochures and data sheets do not guarantee special properties of the products. This does not apply to special product properties confirmed in writing or individually on a case-by-case basis. Subject to technical alterations.